

TECHNICAL DATA

TANDEM ROLLERS

BW 80 AD-5, BW 90 AD-5, **BW 100 ADM-5**

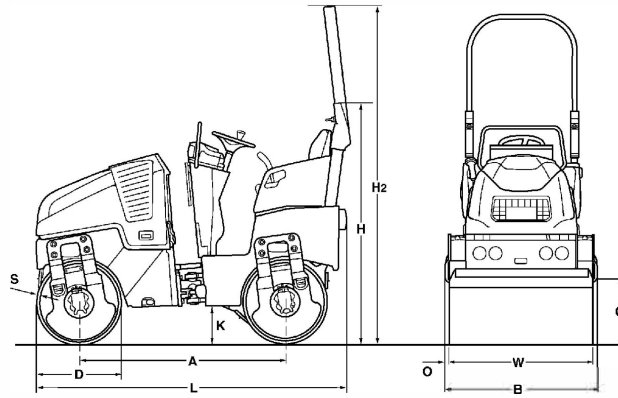



Dimensions in mm

	A	B	C	D	H	H2	K	L	O	S	W
BW 80 AD-5	1483	856	433	580	1627	2304	255	2194	28	13	800
BW 90 AD-5	1483	856	433	580	1627	2304	255	2194	28	13	800
BW 100 ADM-5	1483	1056	433	580	1627	2304	255	2194	28	12	1000

Shipping dimensions in m3

without ROPS

with ROPS

BW 80 AD-5	3,056	4,327
BW 90 AD-5	3,113	4,833
BW 100 ADM-5	3,770	5,338

Machine type	Compaction output (m3/h) at recommended soil layer thicknesses		
	Gravel, sand	Mixed soil	Silt, clay
BW 80 AD-5	60-110	42-85	33-65
BW 90 AD-5	70-120	45-90	35-70
BW 100 ADM-5	75-140	50-100	36-70

Machine type	Compaction output (t/h) at different asphalt layer thicknesses		
	2-4 cm	6-8 cm	10-14 cm
BW 80 AD-5	10-30	25-45	35-70
BW 90 AD-5	15-30	30-50	40-80
BW 100 ADM-5	15-40	35-60	50-90

Technical Data**BOMAG
BW 80 AD-5****BOMAG
BW 90 AD-5****BOMAG
BW 100 ADM-5****Weights**

Operating weight CECE	kg	1.550	1.600	1.700
Average static linear load CECE	kg/cm	9,7	8,9	8,5
Grossweight	kg	1.900	1.900	1.900

Dimensions

Working width	mm	800	900	1.000
Track radius, inner	mm	2.080	2.030	1.980

Driving Characteristics

Speed	km/h	0- 10,0	0- 10,0	0- 10,0
Working speed with vibration	km/h	0- 10,0	0- 10,0	0- 10,0
Max. gradeability without/with vibr. ...	%	40/30	40/30	40/30

Drive

Engine manufacturer		Kubota	Kubota	Kubota
Type		D 902	D 902	D 902
Emission stage		Stage V / TIER4f	Stage V / TIER4f	Stage V / TIER4f
Cooling		water	water	water
Number of cylinders		3	3	3
Performance ISO 14396	kW	15,1	15,1	15,1
Performance SAE J 1995	hp	20,2	20,2	20,2
Speed	min-1	3.000	3.000	3.000
Speed adjustment 1	min-1	2.100	2.100	2.100
Speed adjustment 2	min-1	3.000	3.000	3.000
Electric equipment	V	12	12	12
Driven drum		front + rear	front + rear	front + rear

Brakes

Service brake		hydrost.	hydrost.	hydrost.
Parking brake		hydromec.	hydromec.	hydromec.

Steering

Steering system		oscil.artic.	oscil.artic.	oscil.artic.
Steering method		hydrost.	hydrost.	hydrost.
Steering / oscillating angle +/-	grad	33/8	33/8	33/8
Crab walk	mm	0- 50	0- 50	0- 50

Exciter system

Vibrating drum		front + rear	front + rear	front + rear
Drive system		hydrost.	hydrost.	hydrost.
Frequency	Hz	42/63	42/63	42/63
Amplitude	mm	0,50	0,50	0,40
Centrifugal force	kN	7/17	8/17	8/17

Sprinkler System

Type of sprinkling		pressure	pressure	pressure
--------------------------	--	----------	----------	----------

Capacities

Fuel	l	30,0	30,0	30,0
Water	l	100,0	100,0	100,0

Technical modifications reserved. Machines may be shown with options.